

NOSE LANDING GEAR - MAINTENANCE PRACTICES

1. General

- A. This section gives procedures for the removal/installation of the drag link spring, drag link spring fork and drag link spring support liner. Also included in this section are procedures to inspect and repair the drag link spring, surface rework instructions for the grease seal bore and the cup backing bore, and information about the time limits for the nose gear assembly replacement.
- B. A longitudinal nose gear fairing extends aft that covers the shimmy dampener, upper part of the shock strut and the drag link spring. The shock strut trunnion is attached to the lower forward engine mount at two pivot lugs. The drag link spring is attached at the upper part of the wheel fork and to the lower side of the fuselage using two bearing blocks, in tandem. This arrangement allows for easy removal of the complete nose gear assembly when replacement is required, or when installing floats. For more information about the shimmy dampener, nose gear shock strut and nose gear fairing, refer to Shimmy Dampener - Maintenance Practices, Nose Gear Shock Strut - Maintenance Practices and Nose Gear Fairing - Maintenance Practices.
- C. Vertical loads encountered when you land and taxi are absorbed by the drag link spring and the nose gear shock strut. Minor loads, such as when you taxi, are absorbed primarily by the drag link spring, but as the rate of application of loads increases, such as when you land, a larger and larger proportion of the total load is absorbed by the shock strut. For more information about the nose gear shock strut, refer to Nose Gear Shock Strut - Maintenance Practices.
- D. The nose wheel is steerable through an arc of 15 degrees each side of center by use of the rudder pedals. By applying brakes, the angle may be increased up to 56 degrees either side of center.

2. Drag Link Spring Removal/Installation

- A. Remove the Drag Link Spring (Refer to Figure 201).

NOTE: The nose gear drag link spring is formed to put 150 pounds, +25 or -25 pounds, preload on the extended nose gear strut. Shims are used to adjust the preload.

- (1) Lift the nose of airplane with jacks. Refer to Chapter 7, Jacking - Maintenance Practices.
- (2) Remove the safety wire from the safety clips.
- (3) Remove the bolts that attach the drag link spring fork to the bearing support.
- (4) Pivot the nose gear strut forward to clear the drag link spring fork.
- (5) Release the preload on the drag link spring.
- (6) Keep the safety clip for installation.
- (7) Hold the engine with a hoist and a sling. Refer to Powerplant - General.

NOTE: The hoist and sling will hold the front of the airplane while the jack is removed.

- (8) Remove the nose of the airplane from the jacks. Refer to Chapter 7, Jacking - Maintenance Practices.
- (9) Hold the drag link spring.

(a) If installed, remove the sealant from the forward and aft sides of the forward and aft drag link spring supports.

- (b) Remove the bolts, washers, and nuts that attach the forward drag link spring support to the drag link spring.
- (c) Remove the bolts and washers that attach the aft drag link spring support to the drag link spring.
- (d) Keep the shims, if installed, for installation.

- (10) Remove the drag link spring from airplane.

- B. Install the Drag Link Spring (Refer to Figure 201).

NOTE: The nose gear drag link spring is formed to put 150 pounds, +25 or -25 pounds, preload on the extended nose gear strut. Shims are used to adjust the preload. The maximum thickness of the shims at either drag link spring support must not exceed 0.125 inch.

- (1) Put the drag link spring in position against the airplane.
 - (a) Put the shims, if installed, in position.
 - (b) Install the bolts, washers, and nuts that attach the forward drag link spring support to the drag link spring.
 - (c) Install the bolts and washers that attach the aft drag link spring support to the drag link spring.

- (2) For airplanes 20800553 and on, and airplanes 208B5076 and on, install a fillet seal as follows:

- (a) Install a fillet seal of Type X, Class B on the forward and aft sides of the forward and aft drag link spring supports. Refer to Chapter 20, Fuel, Weather and High-Temperature Sealing - Maintenance Practices.
- (b) Fillet seal around the complete circumference of the spring

NOTE: The minimum fillet seal overlap with the topcoat paint on the spring is approximately 0.25 inch. The fillet seal should cover the entire surface on the support side up to the chamfer.

- (3) Lift the nose of airplane with jacks. Refer to Chapter 7, Jacking - Maintenance Practices.
- (4) Remove the hoist and a sling. Refer to Powerplant - General.
- (5) Measure the distance between the centers of the attach holes in the bearing support and the drag link spring fork. The distance must measure 0.96 inch, +0.13 or -0.13 inch.
 - (a) If the distance is greater, put shim(s), as necessary, between the aft support and the fuselage until the dimension is within the desired dimension.
 - (b) If the distance is less, put shim(s), as necessary, between the forward support and the fuselage until the dimension is within the desired dimension.
- (6) For airplanes 20800260 and on, and airplanes 208B0582 and on, and airplanes that have incorporated CAB96-20, put the safety clips in position on the bearing support.

NOTE: The safety clips must fit tightly against the bearing support surface. The safety clips must not be able to turn.
- (7) Align the bolt attach holes in the drag link spring fork with the holes in the bearing support.
 - (a) Install the bolts and washers that attach the drag link spring fork to the bearing support.
 - (b) Torque the bolts from 60 to 85 inch-pounds.
- (8) Install safety wire on the safety clips.
- (9) Remove the airplane from the jacks. Refer to Chapter 7, Jacking - Maintenance Practices.

3. Drag Link Spring Support Liner Removal/Installation

- A. Remove the Support Liner (Refer to Figure 201).
 - (1) Remove the drag link spring. Refer to Drag Link Spring Removal and Installation
 - (2) Remove the bolt, washer and nut that attach the aft drag link spring support to the drag link spring.
 - (3) Remove the aft drag link spring support from the drag link spring.
 - (4) Remove the forward drag link spring support from the drag link spring.
 - (5) Remove the liner assembly from the forward drag link spring support.
- B. Install the Support Liner (Refer to Figure 201).
 - (1) If the liner is not attached to the bushing, do the steps that follow:
 - (a) Apply Loctite 609 or Loctite 680 Retaining Compound to the interior surface of the bushing.

NOTE: Do not use primer on the bushing.
 - (b) Immediately push the liner into the bushing.
 - (c) Clean off the unwanted Loctite.
 - (2) Push the liner assembly into the forward drag link spring support.
 - (3) Use a staking tool to keep the liner assembly in place. Refer to Chapter 20, Bearings - Removal/Installation.
 - (4) Install the forward drag link spring support on the drag link spring.
 - (5) Install the aft drag link spring support on the drag link spring.
 - (6) Install the bolt, washer and nut that attach the aft drag link spring support to the drag link spring.
 - (7) Install the drag link spring. Refer to Drag Link Spring Removal and Installation.

4. Drag Link Spring Fork Removal/Installation

- A. Remove the Drag Link Spring Fork (Refer to Figure 201).
 - (1) Remove the drag link spring assembly. Refer to Drag Link Spring Removal and Installation.
 - (2) Remove the two bolts, washers, and nuts that attach the drag link spring fork to the drag link spring.
 - (3) Remove the fillet seal from around the complete circumference of the spring and fork assembly. Refer to Chapter 20,

Fuel, Weather and High-Temperature Sealing - Maintenance Practices.

- (4) Remove the spring fork from the drag link spring.
- B. Install the Drag Link Spring Fork (Refer to Figure 201).
 - (1) Prepare the spring surface.
 - (a) Mask approximately 0.25 inch (6.35 mm) from the edge of topcoat on spring.
 - (b) Cut a strip of 1 x 8 inch (25.40 x 203.20 mm) Very Fine Grade "Scotch-Brite"™ abrasive pad.

NOTE: Do not remove the topcoat.
 - (c) Using the strip of Very Fine Grade "Scotch-Brite"™, abrade the unmasked surface to remove the dry film lube or topcoat surface and scuff the topcoat.
 - (d) Solvent wipe the abraded surface with MPK to remove any residue.
 - (e) Using a clean white cloth dampened with Isopropyl Alcohol or a pre-saturated Isopropyl Alcohol wipe, clean the abraded surface. If the wipe has evidence of contamination or residue, repeat the step until the wipes show no evidence of contamination or residue.
 - (f) Remove the tape and solvent wipe the abraded areas and the previously taped areas.
 - (2) Prepare the fitting surface.
 - (a) Using the "Scotch-Brite"™ Very Fine Grade pad, abrade the fitting topcoat paint surface to remove the gloss on the topcoat.
 - (b) Solvent wipe using MPK.
 - (3) Brush coat the abraded surfaces with Type X, Class B sealant. Refer to Chapter 20, Fuel, Weather and High-Temperature Sealing - Maintenance Practices.
 - (4) Insert the drag link spring into the drag link fork and align the bolt holes.
 - (5) Install the two bolts, washers, and nuts that attach the drag link spring fork to the drag link spring. Refer to Chapter 20, Torque Data - Maintenance Practices.
 - (6) Fillet seal around the complete circumference of the spring with Type X, Class B sealant. Refer to Chapter 20, Fuel, Weather and High-Temperature Sealing - Maintenance Practices.

NOTE: The minimum fillet seal overlap with the topcoat paint on the spring is approximately 0.25 inch (6.35 mm). The fillet seal should cover the entire surface on the support side up to the chamfer.
 - (7) After the sealant is cured, prepare and touch-up the paint on the nose landing gear drag link spring. Refer to Nose Landing Gear - Cleaning and Painting.
 - (8) Install the drag link spring assembly. Refer to Drag Link Spring Removal and Installation.

5. Nose Landing Gear Drag Link Spring Inspection/Repair

CAUTION: The damage must not be more than one square inch in area. This repair procedure is applicable for the repair of small areas of damage. Contact Cessna Propeller Aircraft Product Support for repair and replacement instructions for larger areas of damage.

NOTE: The repair procedure that follows may have lower life limits as a cause of the depth of damage that is repaired. Refer to Chapter 4, Replacement Time Limits - Description and Operation.

- A. Do an Inspection of the Nose Landing Gear Drag Link Spring (Refer to Figure 202).
 - (1) Remove the nose gear fairing to get access to the nose landing gear drag link spring.
 - (2) Lift the airplane up on jacks. Refer to Chapter 7, Jacking - Maintenance Practices.
 - (3) Remove the nose landing gear drag link spring. Refer to Drag Link Spring Removal/Installation.
 - (4) Do an inspection of the nose landing gear drag link spring. Refer to Nose Landing Gear - Inspection/Check.
 - (a) If you do not find any damage, then go to step 4.B.(5) that gives instructions to install the nose landing gear drag link spring.
 - (b) If damage is found, then go to the next step to measure the gouged areas of the landing gear spring.
 - (5) Measure the gouged areas of the landing gear spring.

CAUTION: Do not remove paint from the landing gear spring with chemical stripper. If you use chemical stripper, the integrity of the shot peened surface will be compromised.

- (a) Remove only enough paint and surface material to accurately measure the damaged area.

NOTE: Paint and scale or oxide are removed in the immediate area effected by the inspection, to get a correct measurement of the damaged area.

- 1 Use a 180 grit or finer abrasive where heavy layers of scale or oxide are to be removed.
- 2 Use a steel brush or size 150 grit abrasive for any remaining paint, scale or oxide.

CAUTION: Use a pin-type depth micrometer with a tolerance of -0.001 or +0.001 when you measure the depth of the damage. When you measure the depth of the damage, accuracy is very important because of the high possibility of removal of the thin layer of shot peened material.

- (6) Measure and record the difference between the undamaged spring surface and the most severe area of the damage with a pin-type depth micrometer.

- (a) If the measurement is equal to or less than 0.005 inch (0.127 mm), the damage does not need to be blended.

- 1 Prepare and touch-up the paint on the nose landing gear drag link spring. Refer to Nose Landing Gear - Cleaning and Painting.
- 2 Go to step 4.B.(5) that gives instructions to install the nose landing gear drag link spring.

- (b) If the measurement is more than 0.005 inch (0.127 mm), but is less than or equal to 0.075 inch (1.905 mm), repair or replace the nose landing gear spring link.

- 1 If damage is between 0.006 inch (0.152 mm) and 0.050 inch (1.270 mm), the damaged area must be blended out of the nose landing gear drag link spring within the next 200 landings.
 - a If it is necessary for the nose gear drag link spring damage to be blended and an inspection done, then go to Repair the Nose Gear Drag Link Spring.
 - b If it is necessary for the nose gear drag link spring to be blended and have an inspection done at a different time, then prepare and touch up the paint on the nose gear drag link spring as necessary and go to step 4.B.(5) that gives procedures to install the nose landing gear drag link spring.
- 2 If the damage is between 0.051 inch (1.295 mm) and 0.075 inch (1.905 mm), do an inspection of the nose landing gear drag link spring.
 - a Do a magnetic particle inspection. Refer to the Model 208 Nondestructive Testing Manual, Part 8, Nose Landing Gear Spring.
 - b Contact Cessna Propeller Aircraft Product Support at (316) 517-5800 or Fax (316) 942-9006, for more instructions.
- 3 Continued flight is permitted if no cracks are found, but you must obey operational limitations and restrictions while you wait for a Cessna disposition.
 - a Use slow movements when you tow the airplane.
 - b Use only paved runways.
 - c Do not let the landing gear strut compress to the end of its travel, such as during a hard landing or a quick decrease in speed.
 - d If a hard landing or quick decrease in speed that compress the landing gear strut to the end of its travel occur, then replace the nose gear drag link spring before flight.
- 4 If the measurement is more than 0.076 inch (1.930 mm), then replace the nose landing gear drag link spring. Refer to Drag Link Spring Removal/Installation.

- B. Repair the Nose Gear Drag Link Spring (Refer to Figure 202).

- (1) Remove the paint and scale or oxide as necessary to clean the area to be blended.

NOTE: It is necessary to remove only the paint in the area you will repair.

- (a) Use a 180 grit or finer abrasive where heavy layers of scale or oxide are to be removed.
- (b) Use a steel brush or size 150 grit abrasive for any remaining paint, scale or oxide.

CAUTION: Do not exceed 50 PSI when glass bead blasting the surface.

- (2) Only do the bead blasting in the damaged area that needs to be blended.

NOTE: All of the surface will have the same satin finish if it is correctly bead blasted.

CAUTION: Remove only the amount of material necessary. If you remove too much material, you will increase

the damaged area and replacement of the spring may be necessary.

CAUTION: Use small hand-held type tools to do the blending procedures. Do not to do the blending procedures in one area for a long time because the spring material can get too hot in one area and cause damage.

- (3) The damaged area must be blended until you get a smooth transition between the damage and the immediate adjacent areas.
 - (a) Make sure only a minimum amount of material is removed.
 - 1 Use a ratio of 20 to 1 along the vertically blended surface
 - 2 Use a ratio of 5 to 1 across the circumference of the blended surface.
- (4) Measure the deepest part of the damaged area with a pin-type depth micrometer to find the depth of the damaged area to be blended.
 - (a) Refer to the measurement you recorded of the difference between the undamaged spring surface and the deepest area of the damage in step 4.A.(6).
 - 1 If the maximum depth of the damaged area after you blend the surface is 0.055 inch or less, go to step 4.B.(5) that gives instructions to install the nose landing gear drag link spring.
 - 2 If the maximum depth of the damaged area after you blend the surface is greater than 0.055 inch (1.397 mm), contact Cessna Propeller Aircraft Product Support at (316) 942-9006, for more instructions.
 - 3 Continued flight is permitted if no cracks are found, but you must obey operational limitations and restrictions while you wait for a Cessna disposition.
 - a Use slow movements when you tow the airplane.
 - b Use only paved runways.
 - c Do not let the landing gear strut compress to the end of its travel, such as during a hard landing or a quick decrease in speed.
 - d If a hard landing or quick decrease in speed that compress the landing gear strut to the end of its travel occur, then replace the nose landing gear drag link spring before flight.
 - 4 If the maximum depth of the damaged area after you blend the surface is more than 0.075 inch (1.905 mm), then you must replace the nose landing gear drag link spring. Refer to step 4.B.(5) that gives instructions to install the nose landing gear drag link spring.
- (5) Install the nose landing gear drag link spring. Refer to Drag Link Spring Removal/Installation.
- (6) Install the nose landing gear drag link spring fairing. Refer to Nose Gear Fairing - Maintenance Practices.
- (7) Remove the airplane from the jacks. Refer to Chapter 7, Jacking - Maintenance Practices.

6. Nose Wheel Grease Seal Bore And Cup Backing Bore Surface Rework

NOTE: The following procedure covers rework techniques for the nose wheel halves that have developed corrosion or pits on the grease seal bore or cup backing bore surfaces.

A. Removing Pits or Corrosion (Refer to Figure 203).

- (1) Pits or corrosion on the grease seal bore surface or cup backing bore surface can be removed by using 400 grit emery and hand polishing techniques. Care must be taken not to exceed the diameters indicated when working wheels.

NOTE: Do not use shop machinery (lathes, etc.) to clean up corrosion. Use hand polishing techniques.

- (2) If surface pits are removed and pits within the surface remain, they can be removed by glass beading at low pressure, being careful not to remove the parent material on the lip seal bore area. A good quality commercial stripper or acetone may also be used to remove embedded corrosion. Embedded pits must not extend deeper than 0.025 inch below the surface of the bore diameter indicated in Figure 203. If corrosion on surface A of Figure 203 is such that contaminants could enter the bearing bore area, wheel half must be replaced.

B. Returning Bearings to Service (Refer to Figure 203).

- (1) After removing pits or corrosion as best as possible, clean the area with mineral spirits or equivalent solution and dry with filtered compressed air. Because hand polishing or glass beading will have removed most of the anodize coating, it will be necessary to coat surfaces A and B with a protective coating. Chemically film-treat surfaces A and

B using Iridite 14-2 (or equivalent). Brush or swab a liberal coating over bare metal area being worked. Best results are achieved if coating is allowed to set for two to four minutes. Then, thoroughly rinse part with hot water (100°F to 110°F). Allow to dry.

- (2) Within 48 hours of chemical treatment, apply primer (Desoto 513X371 with 910X565 curing solution or equivalent) to surfaces by spraying or hand swabbing, using care not to cover the bearing cup surface C of Figure 203 with primer.
- (3) After adequate curing time (refer to primer manufacturers specifications), the wheels may be returned to service.

7. Nose Gear Assembly Replacement Information

- A. The nose gear assemblies limits information is found in Chapter 4, Replacement Time Limits.
- B. This section shows the nose gear assemblies that you can replace (Refer to Figure 204).

Figure 201 : Sheet 1 : Nose Landing Gear Installation

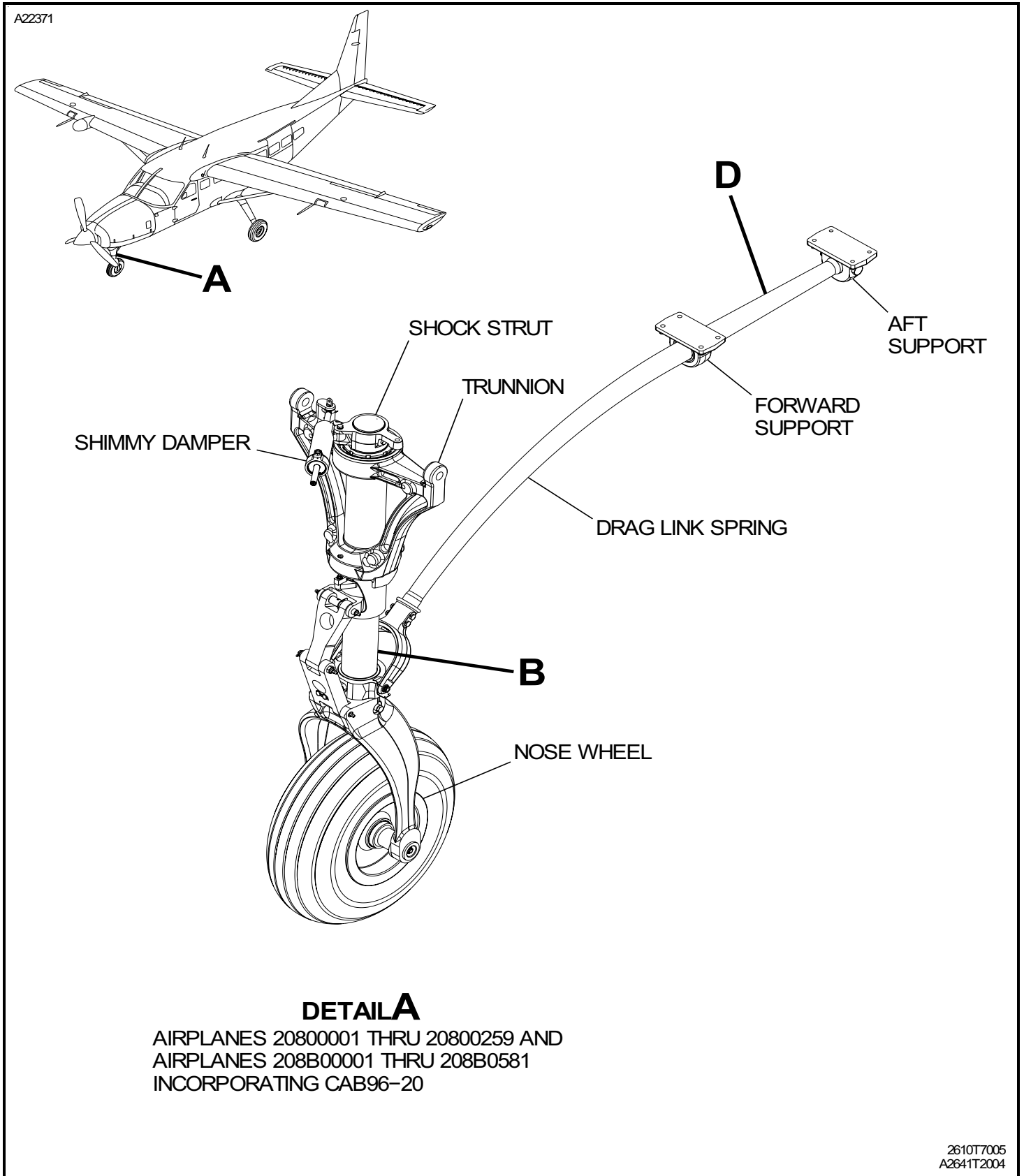
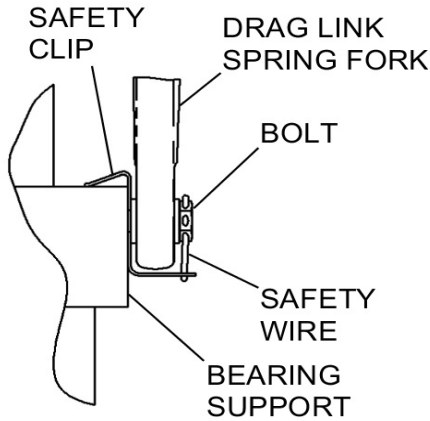

Figure 201 : Sheet 2 : Nose Landing Gear Installation

A22373



VIEW A-A

AIRPLANES 20800260 AND ON AND
 AIRPLANES 208B0582 AND ON

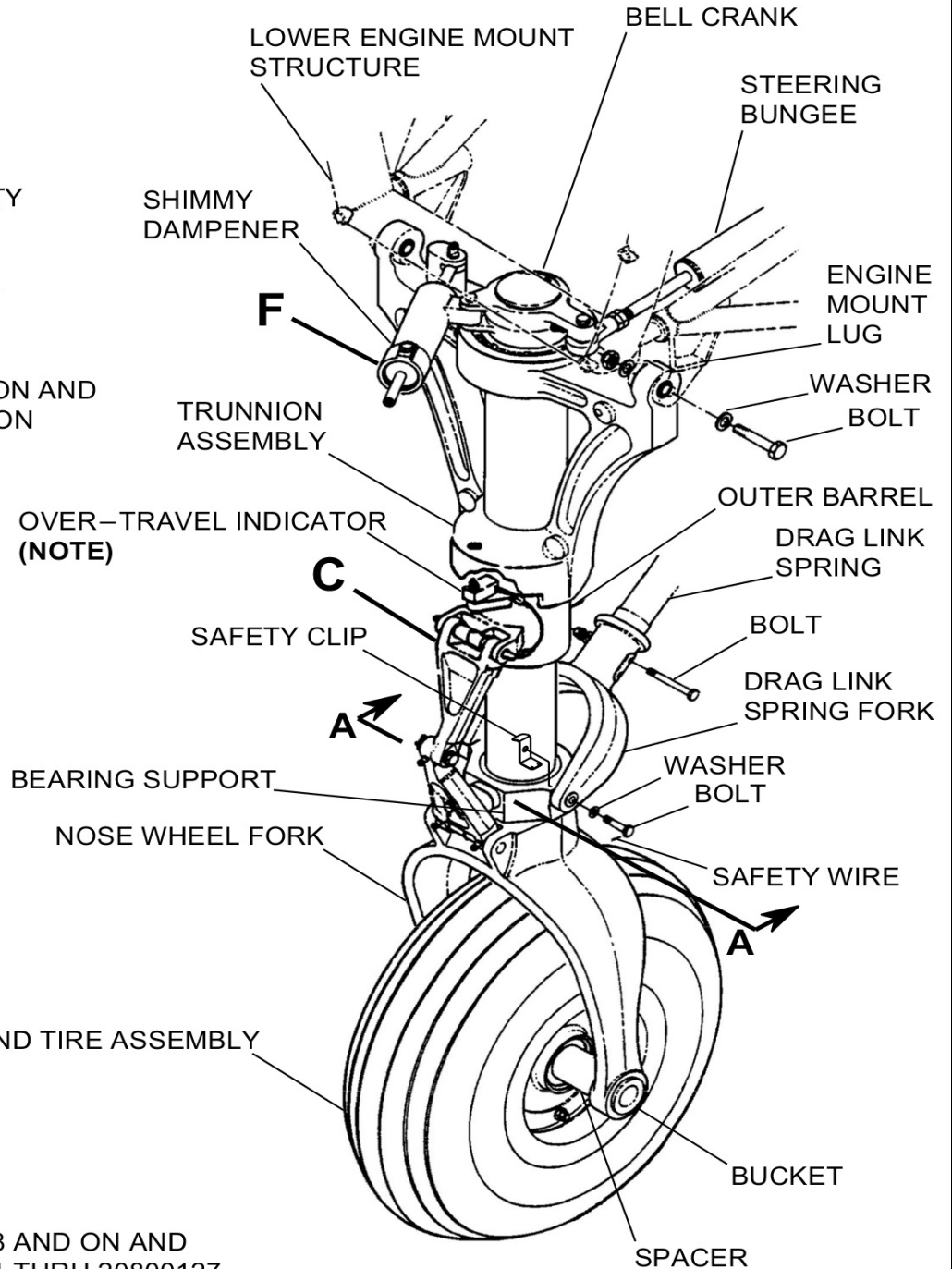

DETAIL B

NOTE: AIRPLANES 20800128 AND ON AND
 AIRPLANES 20800001 THRU 20800127
 INCORPORATING SK208-48

AIRPLANES 208B0055 AND ON AND
 AIRPLANES 208B0001 THRU 208B0054
 INCORPORATING SK208-48

B2642R4001
 AA2642R1003

Figure 201 : Sheet 3 : Nose Landing Gear Installation

A22367

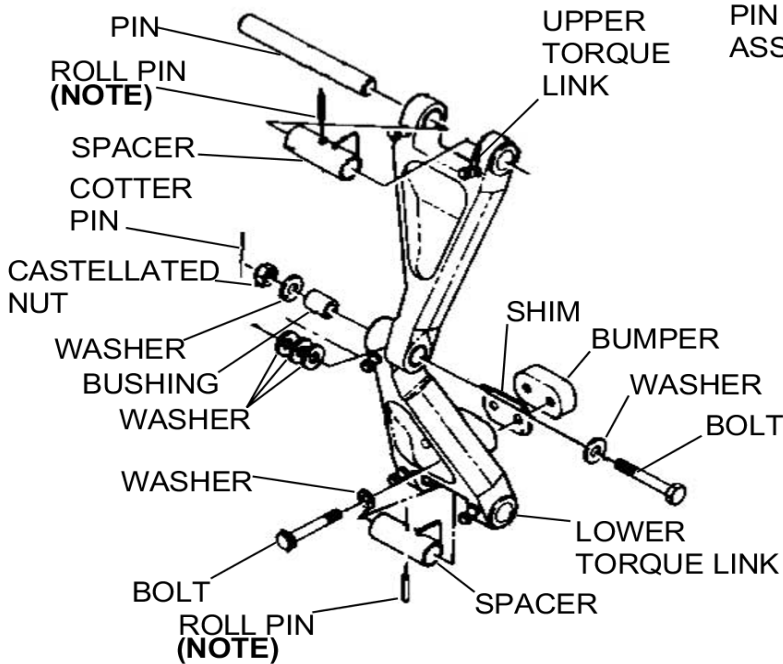

DETAIL C

AIRPLANES 20800001THRU 20800133
 EXCEPT AIRPLANES INCORPORATING SK208-51 AND
 AIRPLANES 208B0001 THRU 208B0098
 EXCEPT AIRPLANES INCORPORATING SK208-51

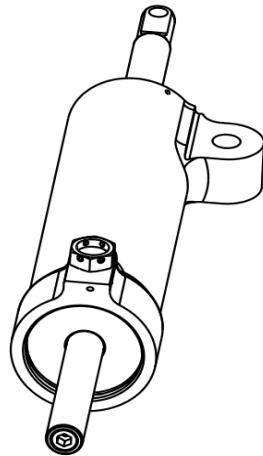

DETAIL F

AIRPLANES 20800001 THRU 20800393 AND
 AIRPLANES 208B0001 THRU 208B1139

NOTE: SAFETY WIRE REMOVED
 FOR CLARITY

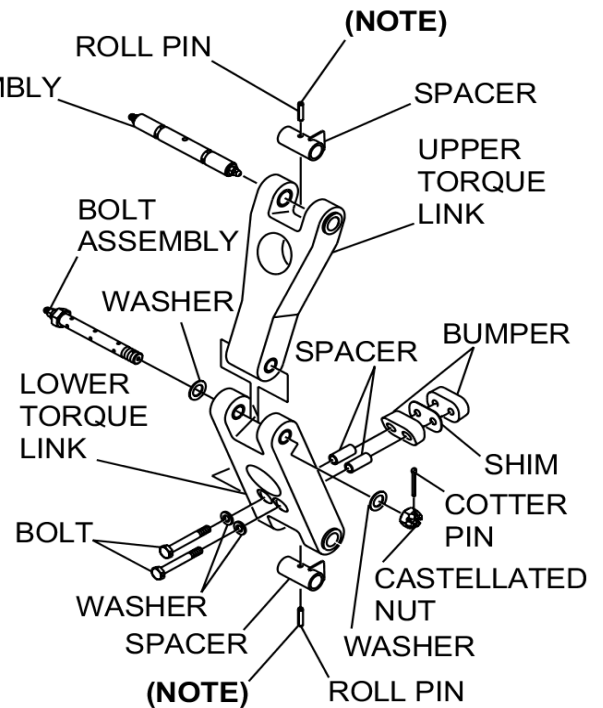

DETAIL D

AIRPLANES 20800134 AND ON AND
 20800001 THRU 20800133
 INCORPORATING SK208-51 AND
 AIRPLANES 208B0099 AND ON AND
 208B0001 THRU 208B0098
 INCORPORATING SK208-51

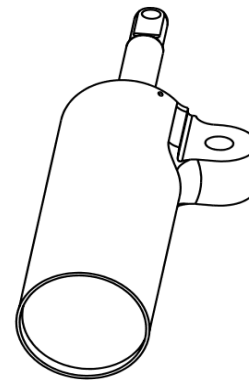

DETAIL F

AIRPLANES 20800394 AND ON AND
 AIRPLANES 208B1140 AND ON

C26424002
 C2614T1359
 F2642T1014
 F2642T1015

Figure 201 : Sheet 4 : Nose Landing Gear Installation

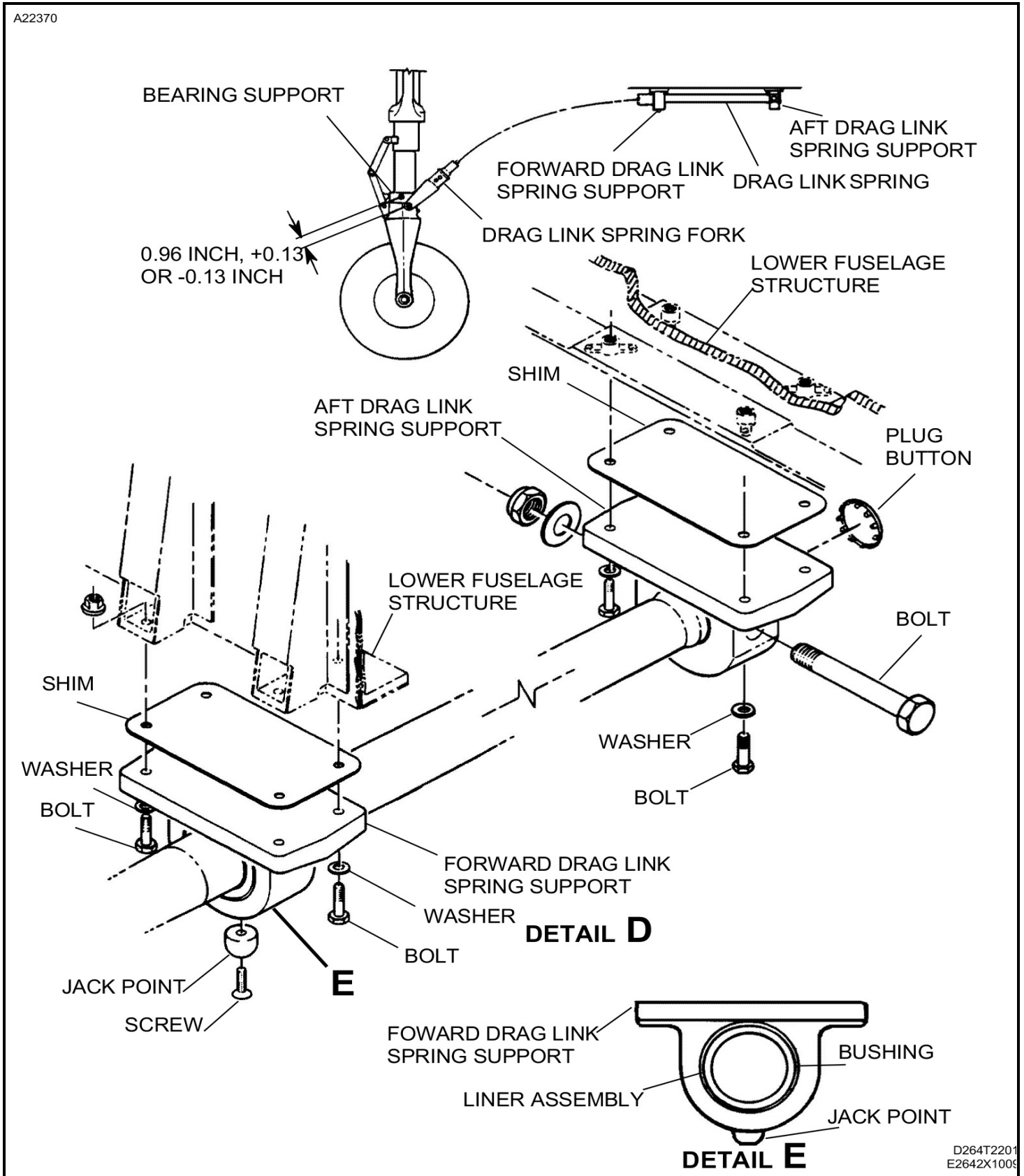

Figure 202 : Sheet 1 : Nose Landing Gear Drag Link Spring Inspection/Repair

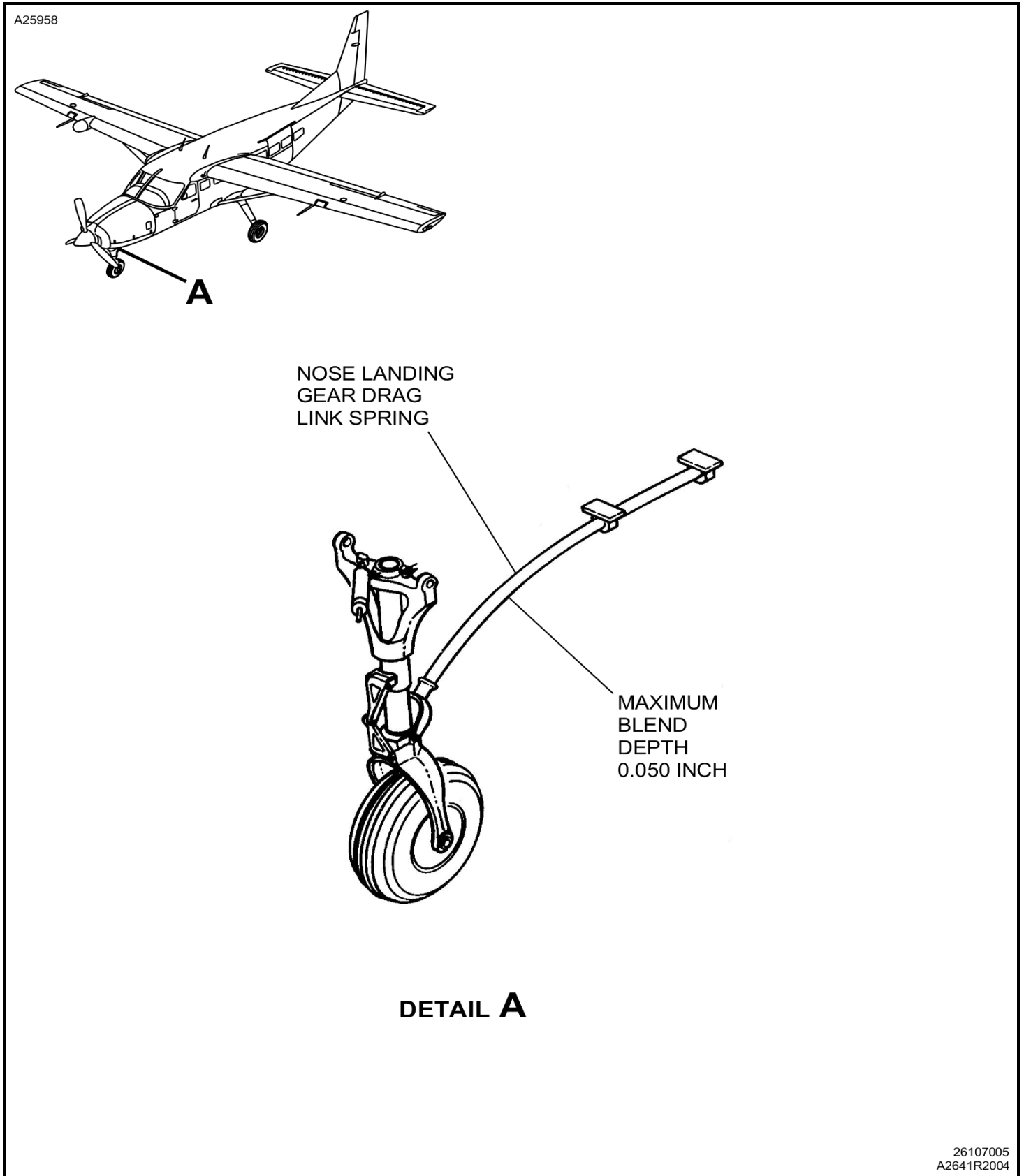
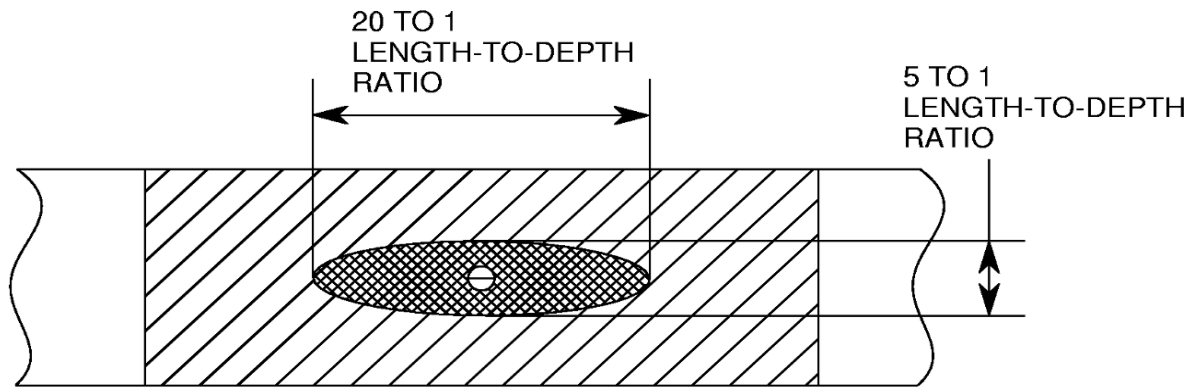

Figure 202 : Sheet 2 : Nose Landing Gear Drag Link Spring Inspection/Repair

A25960



DETAIL B
TYPICAL COMPLETED BLENDING REPAIR

B2614T1017

Figure 203 : Sheet 1 : Wheel Hub and Bearing Cutaway

A22381

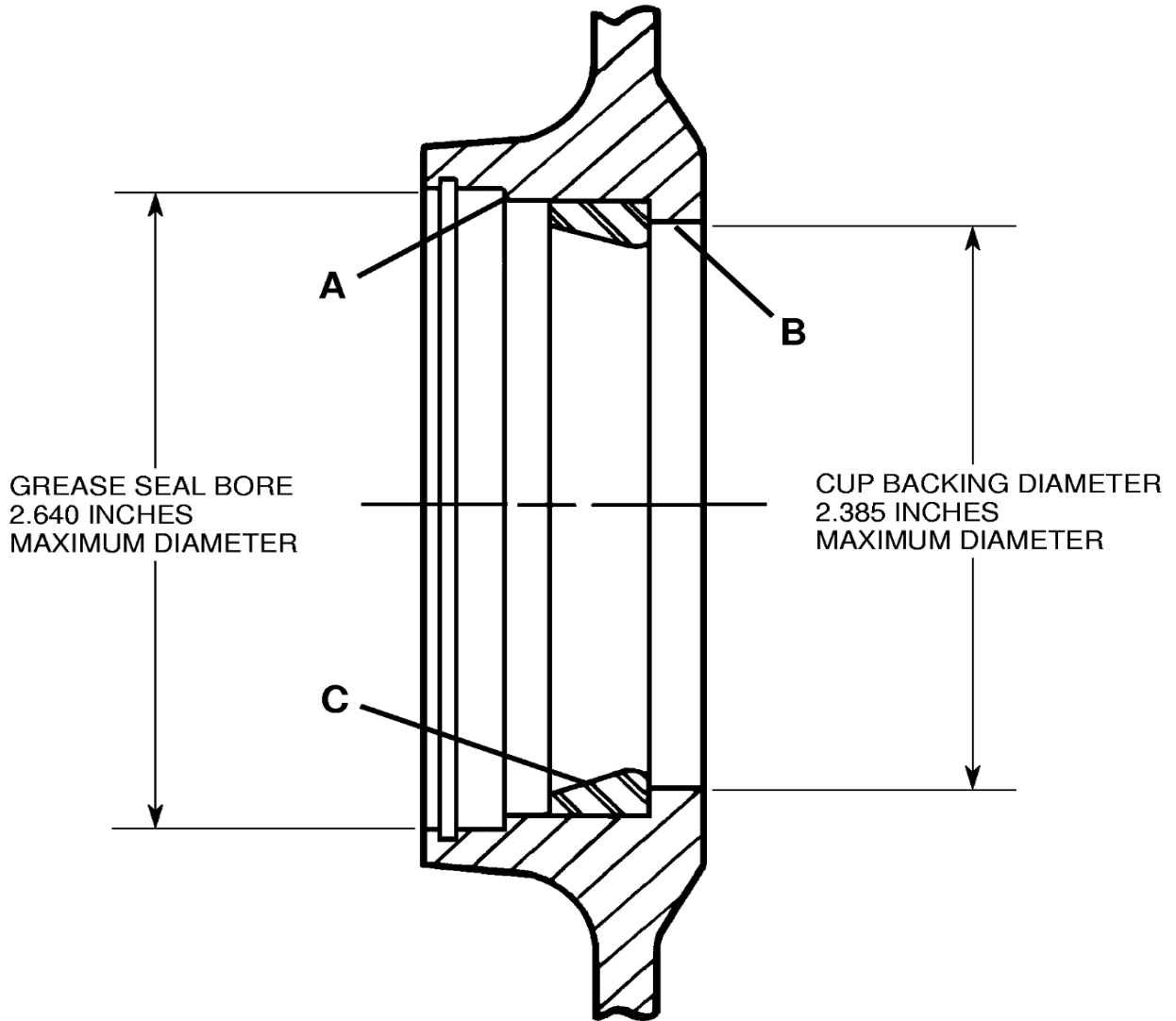

- A = GREASE SEAL BORE SURFACE
- B = CUP BACKING BORE SURFACE
- C = BEARING CUP SURFACE

26421010

Figure 204 : Sheet 1 : Nose Gear Replacement Assemblies

